

- Announcements
- Project Proposal
- AVR Processor Resources
  - A/D Converter (Analog to Digital)
  - Analog Comparator
  - Real-Time clock using Timer 2



- Lab#2 in progress
  - Due date: **Monday Oct 14, 5pm**
- Projects
  - Arrange to meet and discuss your ideas
  - Project Proposal: **Due Friday Oct 25, 5pm**



- 1-2 page proposal including:
  - Name of your project
  - Team members
  - Project description
    - Be sure to cover *at least* what purpose your project serves, how you expect it to work or how someone will use it, how it will look (use graphics), how the user will interact with the project (inputs and outputs), what features of the AVR processor you intend to use, how you will write your code (asm, C, mixed), and how you will build your project (wire-wrap, perf-board, hand-soldered, case?)
  - List of important parts
    - Should include all major/critical parts or modules
    - List real part numbers, not just descriptions
    - Don't forget to include the AVR processor you intend to use
  - Areas in which you might need help



- Interrupts
- Timers
- UART (Universal Asynchronous Receiver/Transmitter)
- SPI (Serial Peripheral Interface)
- A/D Converters (Analog to Digital)
- Analog Comparator



- General Purpose Ports
  - PORTA (A/D conv)
  - PORTB
  - PORTC
  - PORTD
  - (Special Functions)
- Special Purpose Pins
  - Crystal (XTAL1/XTAL2)
  - Real Time Crystal (TOSC1/2)
  - RESET
  - AREF, AVCC, AGND
- Power (VCC/GND)

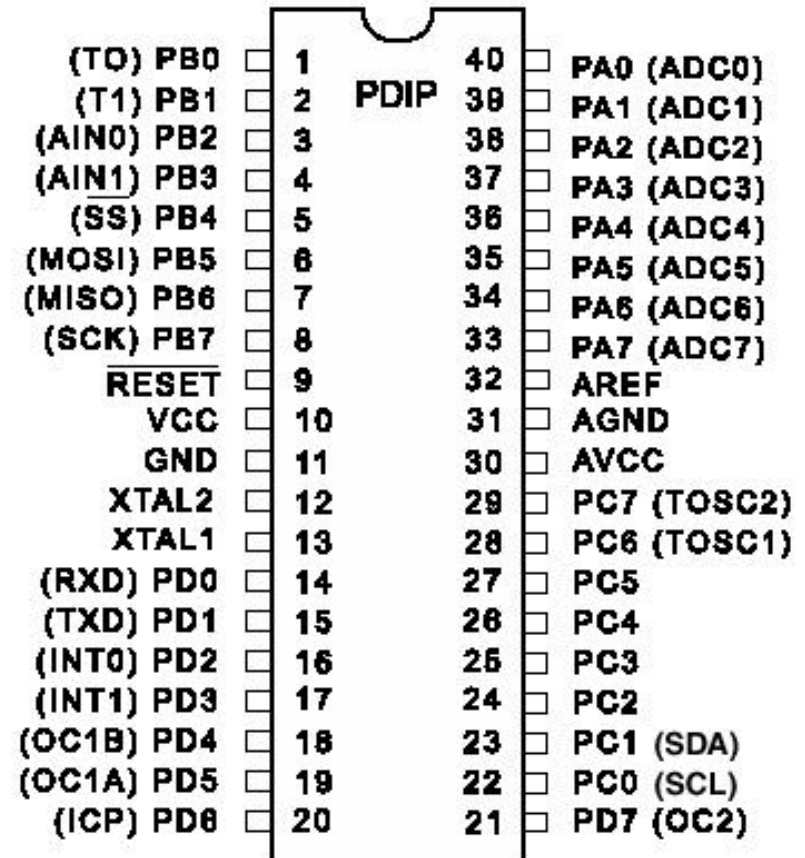

- 32 Registers (R0-R31)
- 8 Kw Prog ROM
- 1 Kb RAM
- 512 bytes EEPROM
- 32 I/O lines
- 18 Interrupts
- **A/D Converter**
- **Timer 2**
- **I<sup>2</sup>C Bus**

(Mega323 doubles ROM/RAM/EEPROM memories)

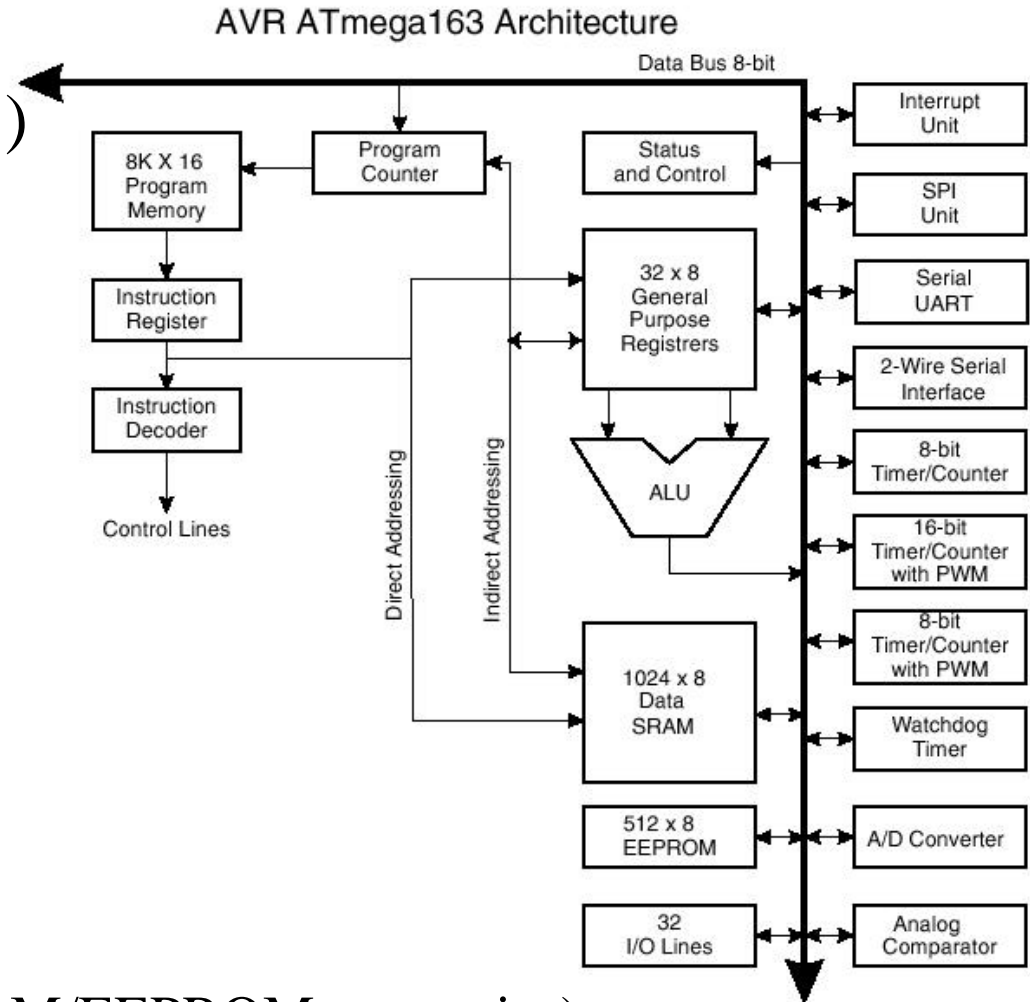

- An A/D converter converts a sensed analog voltage into a binary value
  - Example: 0-5V might convert to 0-255 binary
- The mega163/323 A/D converters provide:
  - Successive-Approximation conversion
  - 8 channels (inputs)
  - 8, 9, or 10 bits resolution (1 LSB typical accuracy)
  - 65-260us conversion time
  - Single-conversion or Free-Running mode
  - Conversion Complete Interrupt



- **ADCH/ADCL (A/D Result Register)**
  - Read the high and low portion of the conversion result from these registers
- **ADCSR (A/D Control and Status Register)**
  - A/D Enable bit
  - A/D Start Conversion bit
  - A/D mode select (single conversion or free-run)
  - Set A/D Converter clock rate (prescaler)
  - Interrupt Enable, Mask, and Flag bits
- **ADMUX (A/D Multiplexer Register)**
  - Select your input channel (input pin)
  - Select a voltage reference





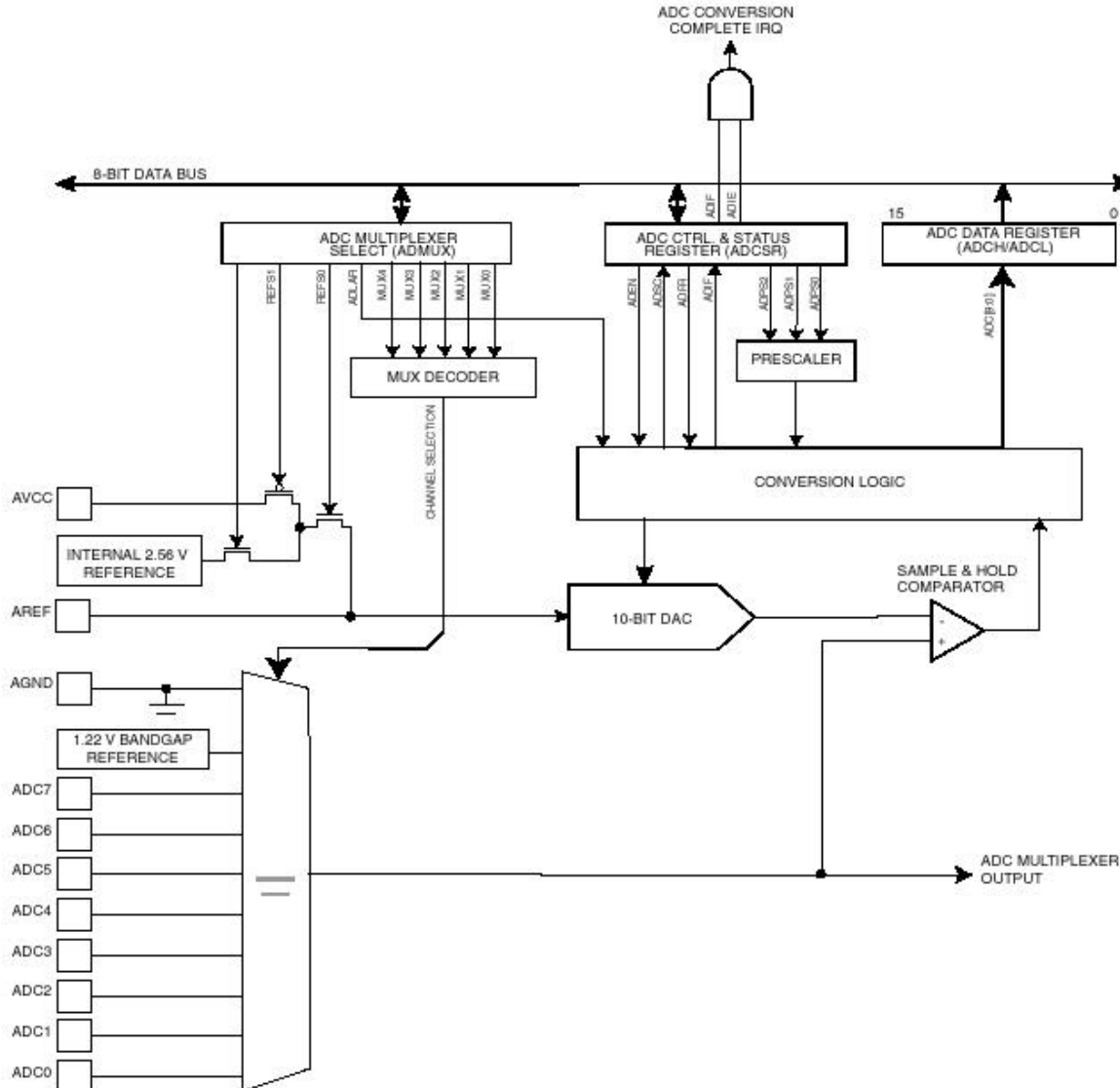

- Input ranges and VREF
  - A reference is required to make any measurement
  - VREF is the reference voltage against which A/D inputs are measured (internal 2.56V or external VREF pin)
  - Analog input range of the A/D converters is 0-VREF volts
- Output ranges
  - The output range is defined by the number of bits the A/D converter produces across its input range
    - 0-VREF  $\rightarrow$  8 bits  $\rightarrow$  0-255 (Resolution = VREF/256)
    - 0-VREF  $\rightarrow$  9 bits  $\rightarrow$  0-512 (Resolution = VREF/512)
    - 0-VREF  $\rightarrow$  10-bits  $\rightarrow$  0-1024 (Resolution = VREF/1024)

Example:            VREF = 2.56V    Conv. output = 120  
Voltage in was  $(120/256)*VREF = 1.2V$



- With a potentiometer or joystick

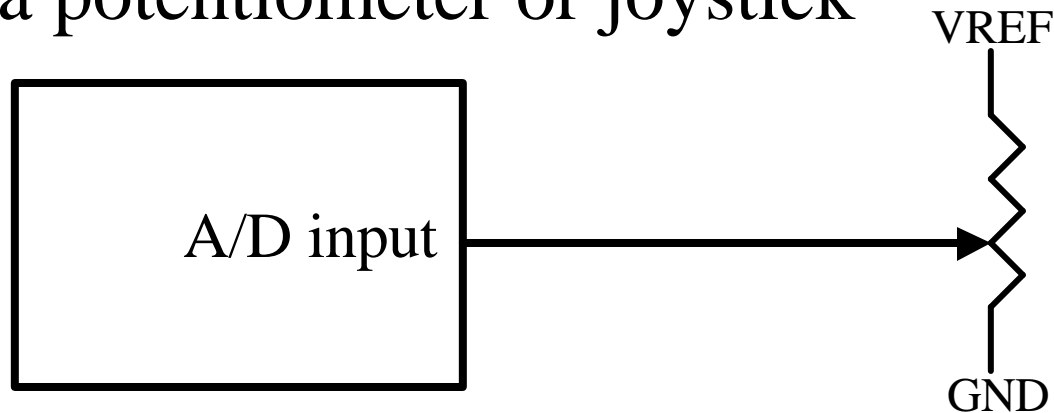

- With a sensor

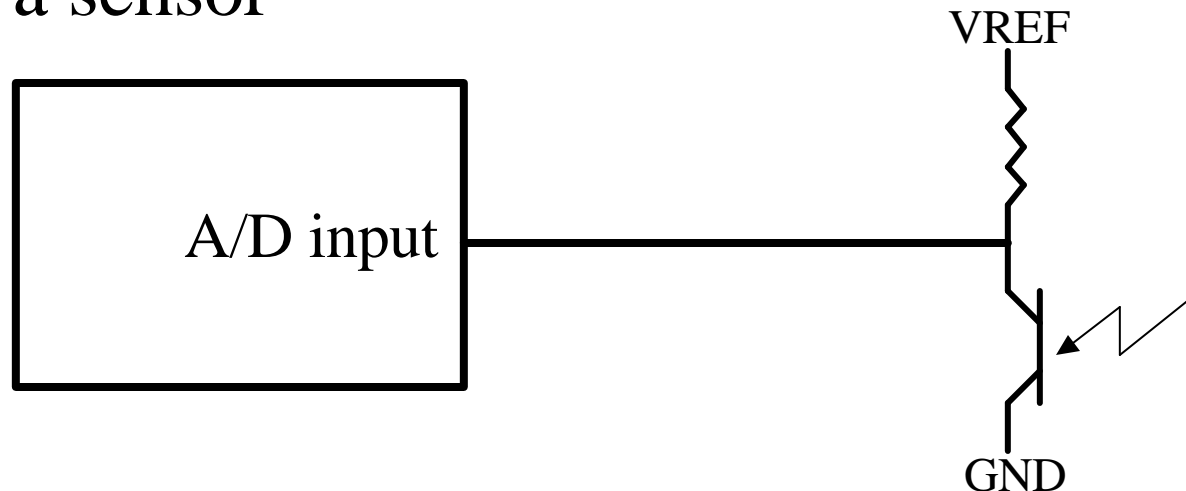

- Compares voltages on AIN0 and AIN1
- Reports which is greater
- Can trigger interrupt on:
  - $AIN0 > AIN1$
  - $AIN0 < AIN1$
  - Both
- ACSR (Analog Comparator Status Register)
  - Select source of input
  - Enable/Disable interrupt
  - Select interrupt condition



- Mega163/323 includes an extra 8-bit Timer 2
- Timer 2 is designed to be able to operate as a Real-Time Clock
  - Connect 32.768KHz crystal between TOSC1/2
  - Set Timer 2 prescaler to use external crystal as input
  - Set Prescaler division ratio to provide overflow at convenient intervals (like 1Hz)
  - Use the OVFL interrupt service routine to keep track of time in ordinary HH:MM:SS

