

a course about information

it's all about the information: take I

- you write an essay
- can save on your computer
- or on a memory stick
- or in the cloud
- or send the file to another computer
- or write on and save the paper
- or scan the paper into a file
- etc.

what is the essay?

same for your books, music, photos, videos, money, medical records, memories, etc.

it's all about the information: take II ship of Theseus

- imagine the ship
- replace its parts one by one
- what do we get in the end?



what is the ship?

same for anything else “physical” you care about

**it's all about the information: take III
you!**

- you are like Theseus' ship

who are you? what are you?

this course is for you about you!

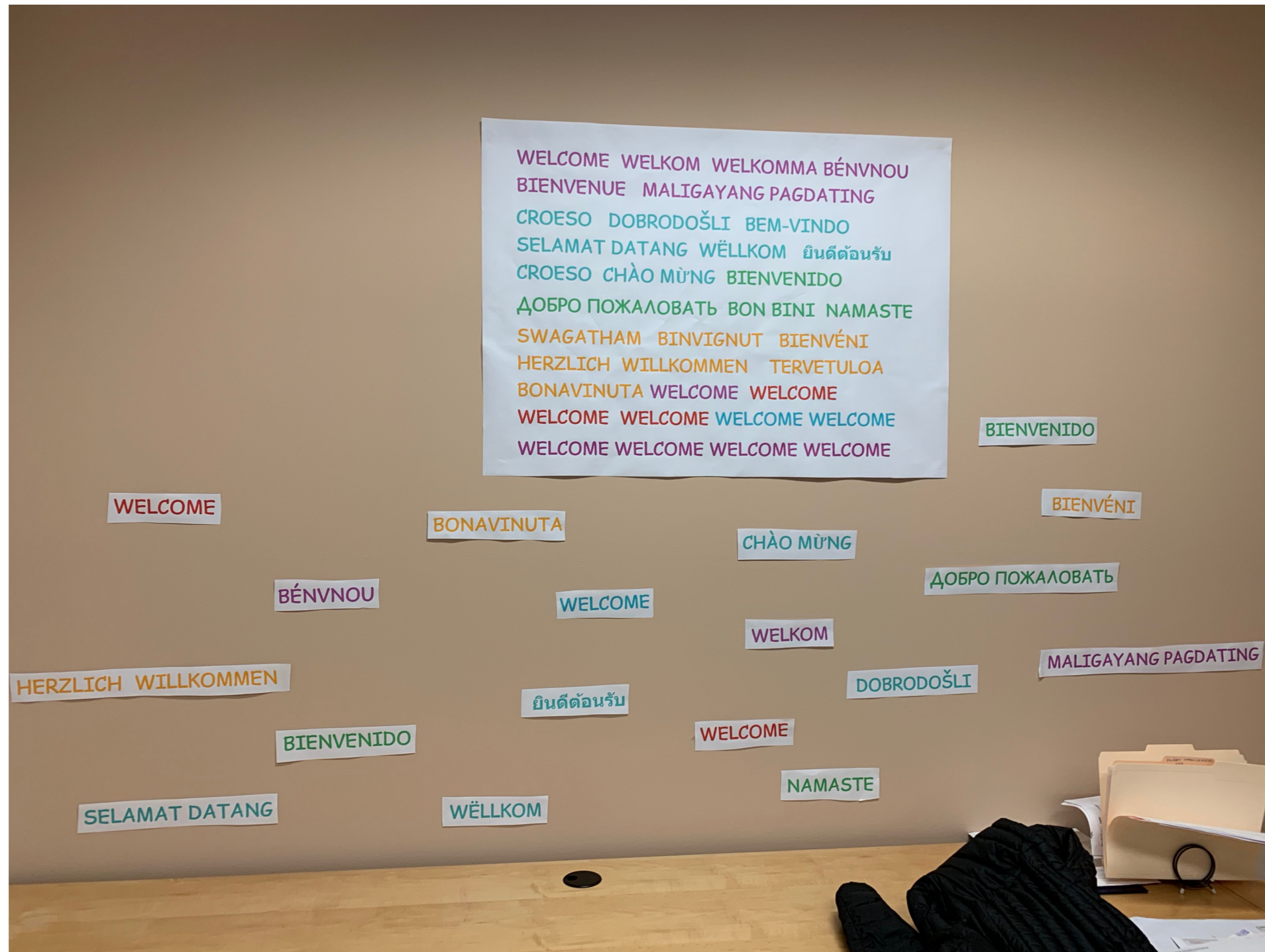

(with thanks to Tiffany Tran)

target demographic

- “from the techies to the lit. majors”, Rob Reid, After On podcast
- anyone who wants to understand the basics of the science of information and some of its applications/manifestations

goal

- expose the beauty and utility of the science of information, at a level you can relate to and appreciate
- equip those so inclined and motivated with the knowledge and tools to apply information theory in their research or work
- to be a prerequisite for subsequent courses in information theory

EE376a

**a course about the science of information
aka “information theory”**

what is science?



SINCE 1828

science

DICTIONARY

THESAURUS

LEGAL



Switching to Allstate is worth it.

Save on home insurance by talking to an Allstate Agent today.

Find An Agent

science

noun | sci·ence | \ˈsī-ən(t)s\

Popularity: Top 1% of lookups | Updated on: 31 Aug 2018

TRENDING NOW: [hirsute](#) [op-ed](#) [collegiality](#) [mistrial](#) [hogwash](#) [SEE ALL >](#)

[Examples: SCIENCE in a Sentence](#) ▾

Definition of SCIENCE

- 1 : the state of knowing : knowledge as distinguished from [ignorance](#) or misunderstanding
- 2 **a** : a department of [systematized](#) knowledge as an object of study • the *science* of theology
b : something (such as a sport or technique) that may be studied or learned like systematized knowledge • have it down to a *science*
- 3 **a** : knowledge or a system of knowledge covering general truths or the operation of general laws especially as obtained and tested through [scientific method](#)
b : such knowledge or such a system of knowledge concerned with the physical world and its [phenomena](#) : [NATURAL SCIENCE](#)
- 4 : a system or method [reconciling](#) practical ends with scientific laws • cooking is both a *science* and an art
- 5 *capitalized* : [CHRISTIAN SCIENCE](#)

what is information?



SINCE 1828

information

DICTIONARY

THESAURUS

information

noun | in·for·ma·tion | \,in-fər-'mā-shən\

Popularity: Top 1% of lookups | Updated on: 3 Sep 2018

TRENDING NOW: [hirsute](#) [op-ed](#) [collegiality](#) [mistrial](#) [hogwash](#) [SEE ALL >](#)

[Tip: Synonym Guide](#) ▾

[Examples: INFORMATION in a Sentence](#) ▾

Definition of INFORMATION

- 1 : the communication or reception of knowledge or intelligence
- 2 **a** (1) : knowledge obtained from investigation, study, or instruction (2) : [INTELLIGENCE](#), [NEWS](#) (3) : [FACTS](#), [DATA](#)
b : the attribute inherent in and communicated by one of two or more alternative sequences or arrangements of something (such as nucleotides in DNA or binary digits in a computer program) that produce specific effects
c (1) : a signal or character (as in a communication system or computer) representing data (2) : something (such as a message, experimental data, or a picture) which justifies change in a construct (such as a plan or theory) that represents physical or mental experience or another construct
d : a quantitative measure of the content of information; *specifically* : a numerical quantity that measures the uncertainty in the outcome of an experiment to be performed
- 3 : the act of [informing](#) against a person
- 4 : a formal accusation of a crime made by a prosecuting officer as distinguished from an indictment presented by a grand jury

—informational  \,in-fər-'mā-shnəl, -shə-nəl\ *adjective*

—informationally *adverb*

what is 'science of information'?

knowledge of communication of knowledge?!

communication!

what is communication?



MITOSIS

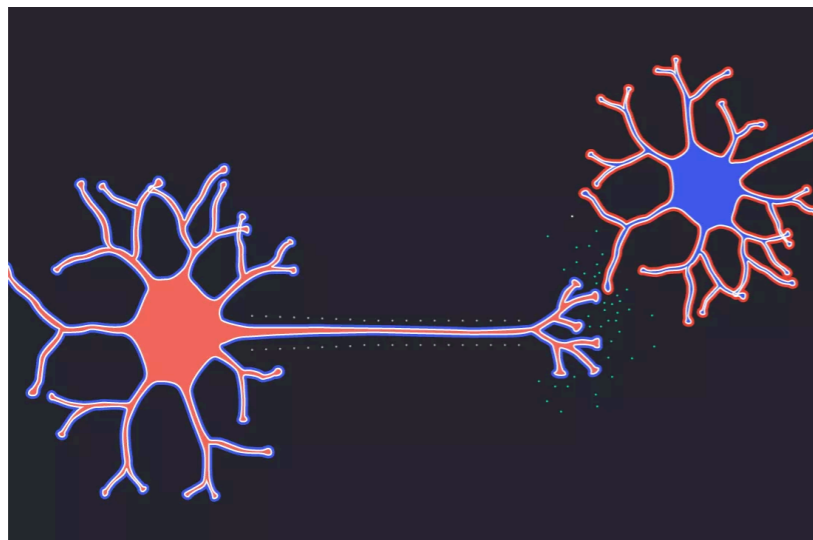
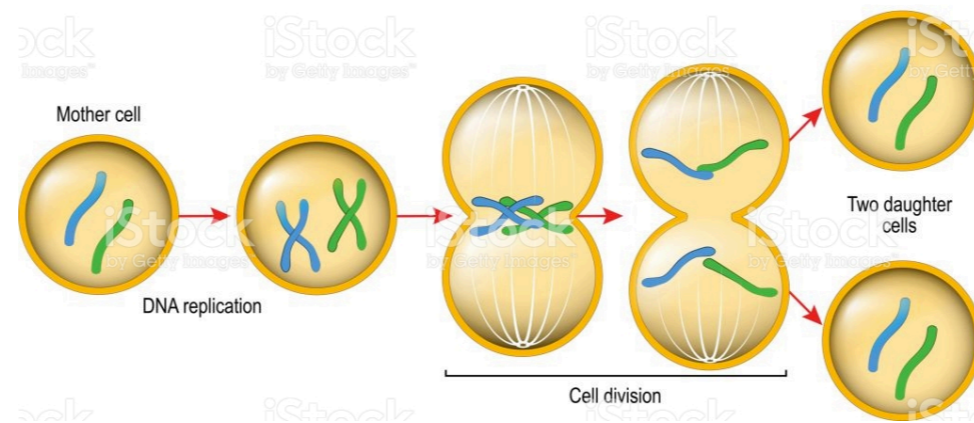

Claude Elwood Shannon

1948

A Mathematical Theory of Communication

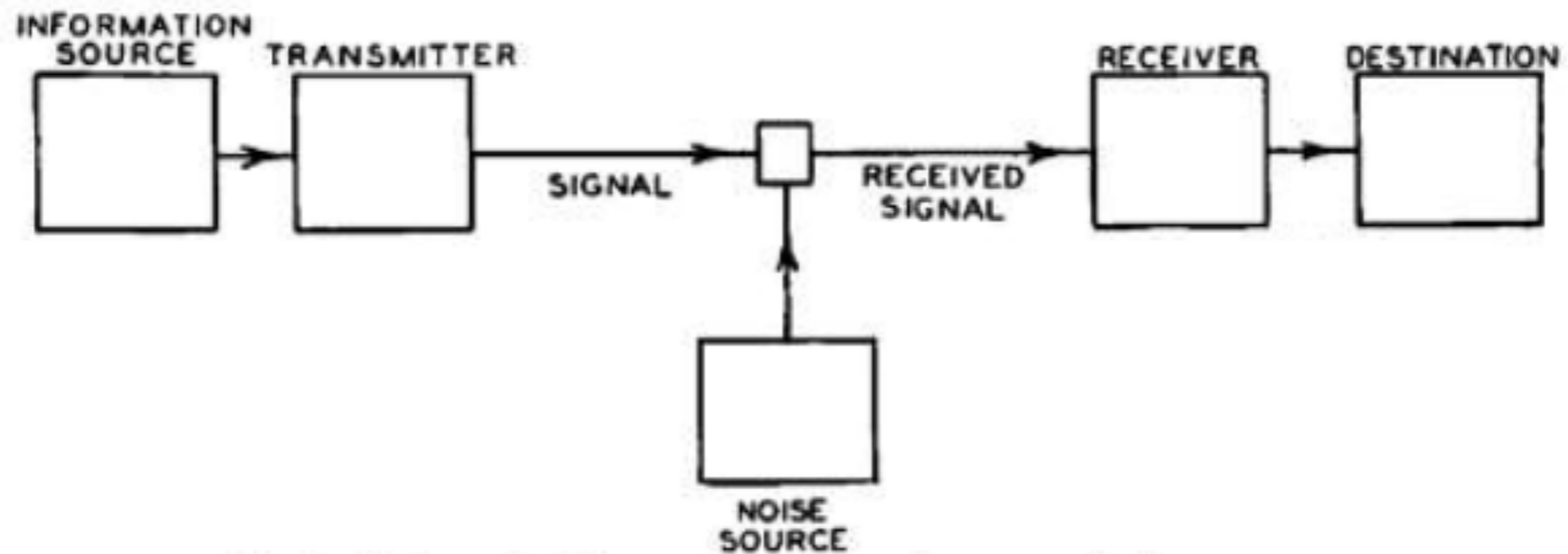
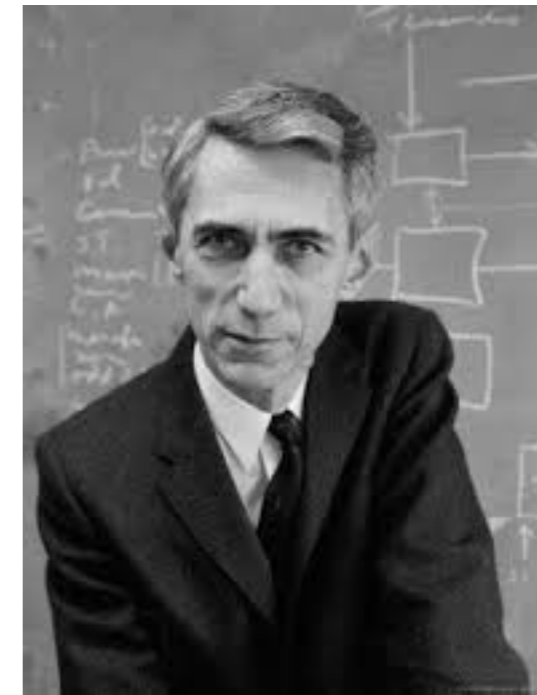

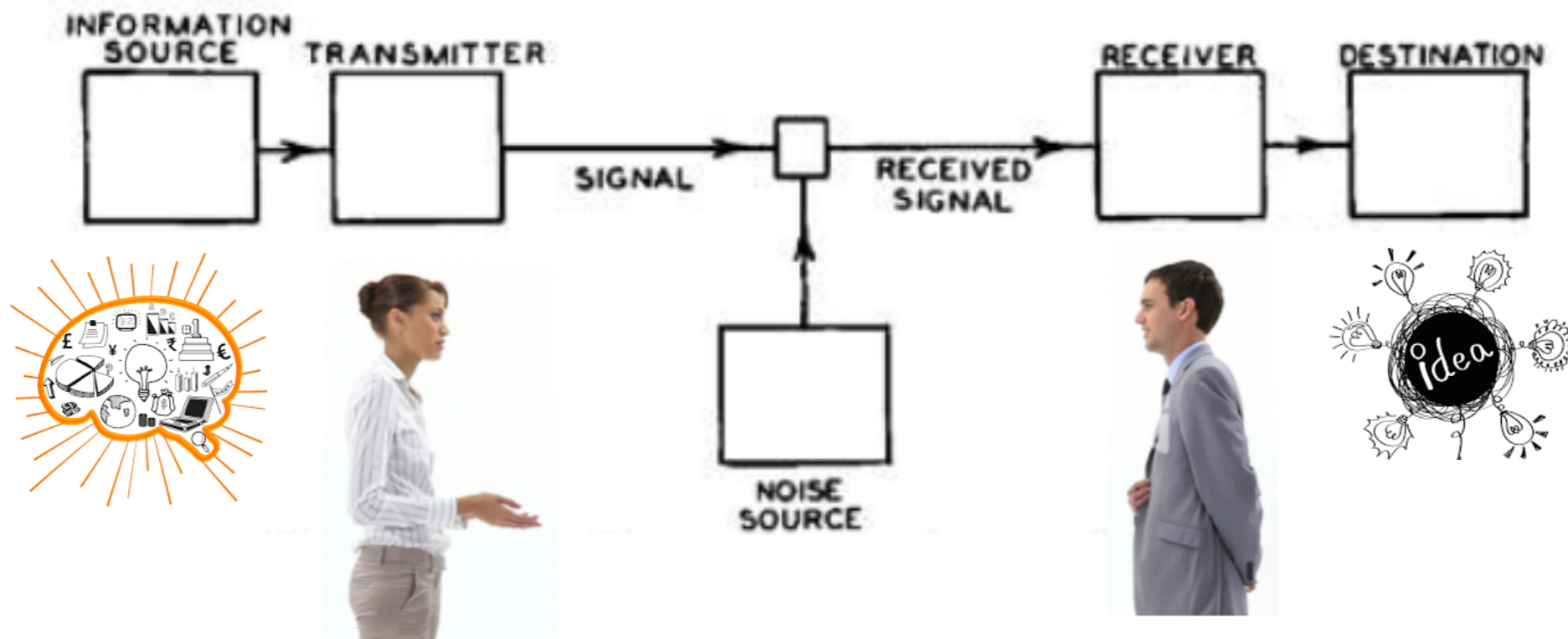

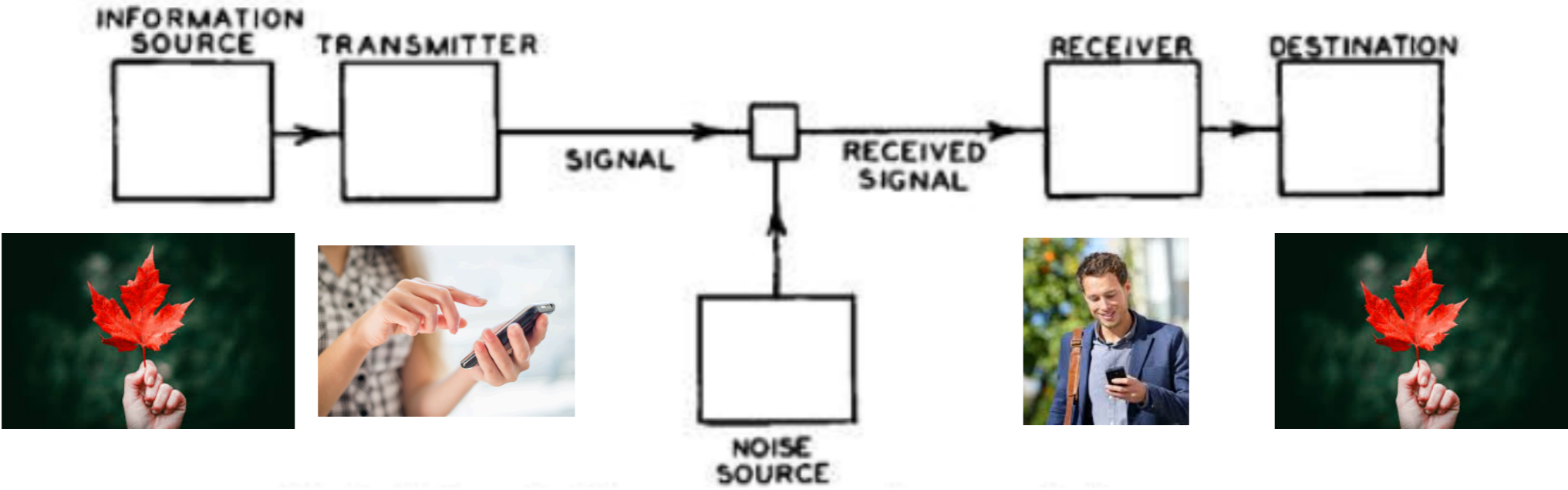

Shannon's genius

- the question
- the answer

a bit about the bit

0 or 1

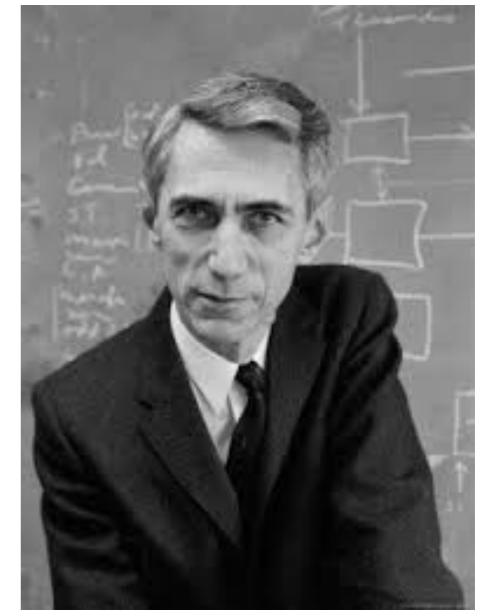

2 pillars of the science of information

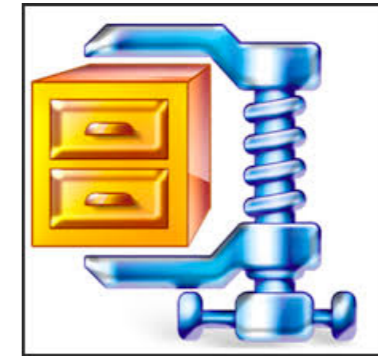

- succinct representation in bits (compression)
- effective and reliable communication of bits (across unreliable media)



**Shannon discovered the two,
and that combining them is optimal**

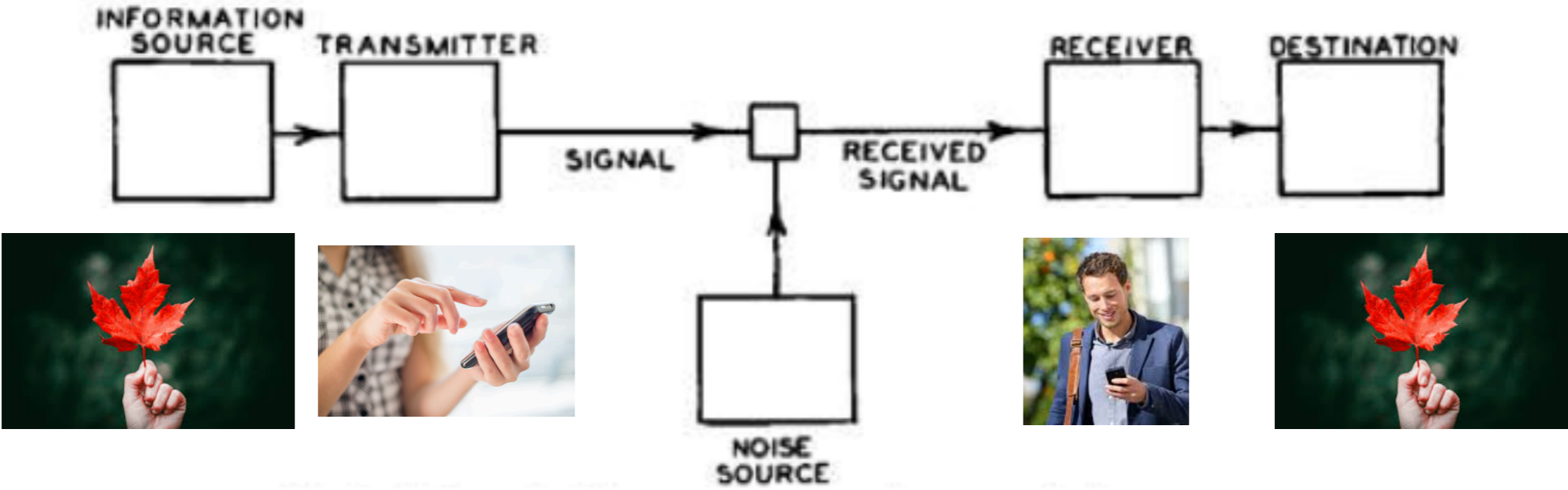

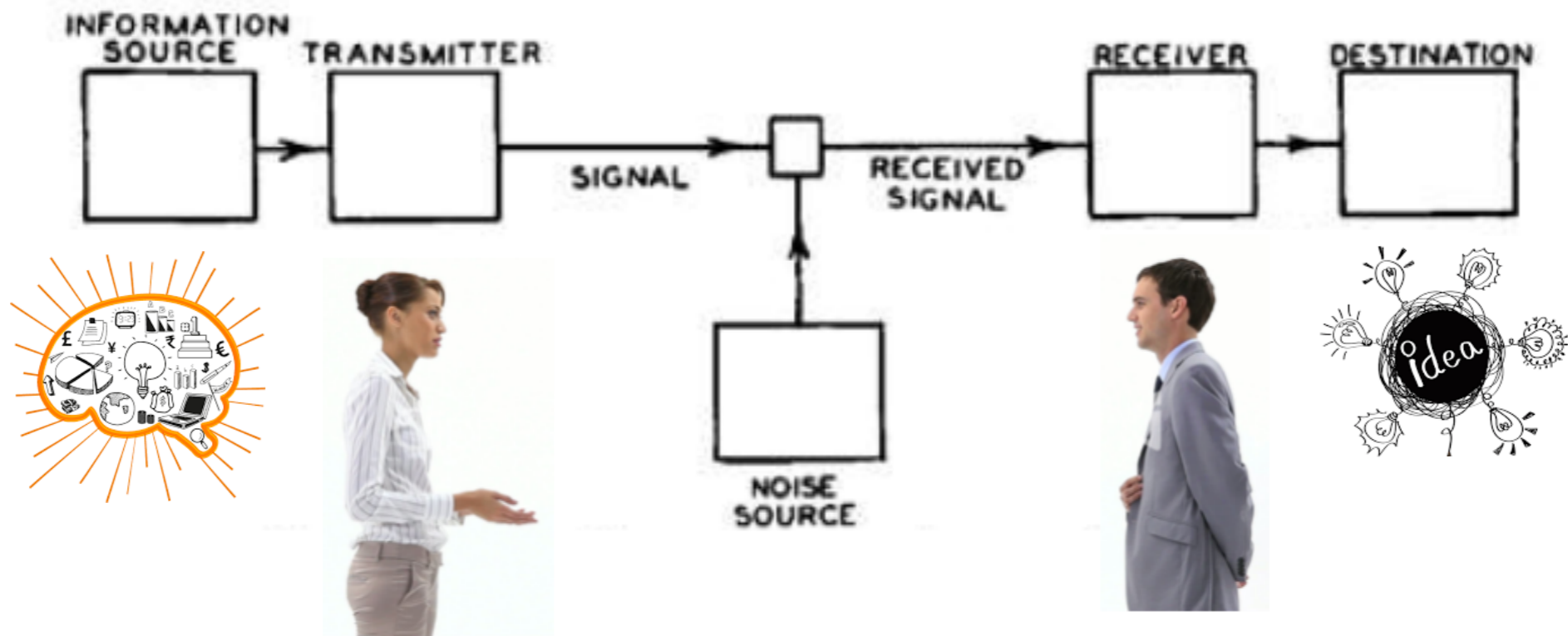

and everything else

- neurons
- genetics
- music
- emotions
- colors
- algorithms/code
- text
- matter
- energy
- space-time
- etc.

course theme I: communication

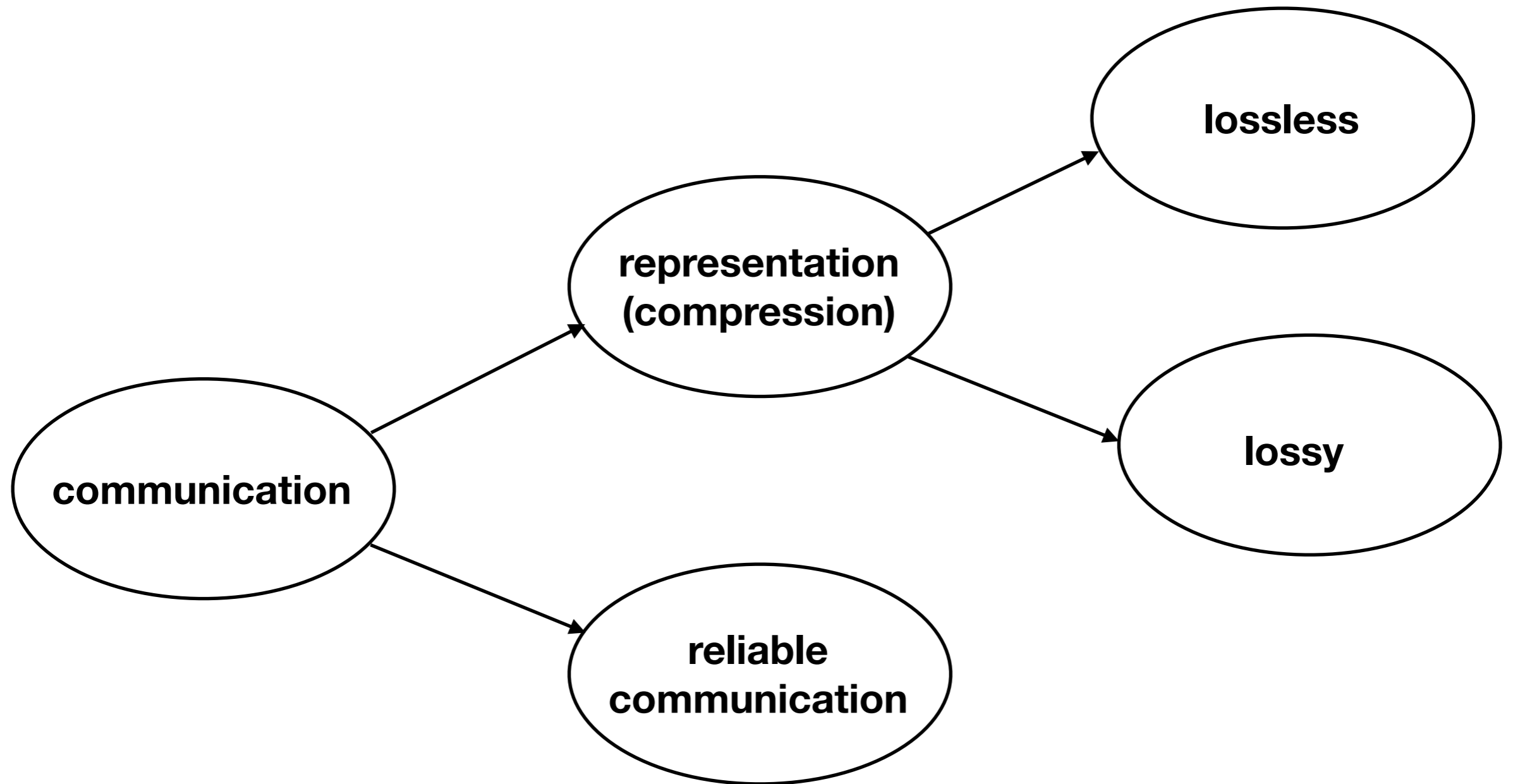

course theme II: concrete schemes

- Shannon, Huffman
- Lempel-Ziv (GZIP)
- Humans for lossy compression
- Polar codes for reliable communication (5G)

course theme III: measures of information

- entropy
- relative entropy
- mutual information
- Shannon capacity and rate-distortion function

course theme IV: relations to and manifestations in other areas

- neuroscience
- genomics
- machine learning
- cryptocurrency
- quantum information
- arts
- humans
- entertainment

lecture schedule

- lecture 1: Intro
- lecture 2: Measures of information and their properties
- lecture 3: Asymptotic Equipartition Property (AEP) and near-lossless compression
- lecture 4: Variable length compression: Shannon and Huffman codes, Kraft inequality, Entropy lower bound
- lecture 5: Human genome + tabular compression (Dmitri Pavlichin)
- lecture 6: Reliable communication I: channel capacity, examples
- lecture 7: Reliable communication II: random coding
- lecture 8: From STEM to STEAM (Bianka Hofmann)
- lecture 9: Polar codes (Mert Pilanci)
- lecture 10: Lossy compression I: rate-distortion function, examples
- lecture 11: Lossy compression II: direct and converse parts of main result
- lecture 12: Lempel-Ziv compression: without and with side information (Yeohee Im)
- lecture 13: Genomic data compression for large and growing databases (including Slepian-Wolf compression and denoising via lossy compression)
- lecture 14: The separation theorem
- lecture 15: Information flow in the brain (Rosa Cao)
- lecture 16: Machine learning via and for Information Theory (Kedar Tatwawadi)
- lecture 17: Humans are awesome communicators/compressors (Irena Hwang)
- lecture 18: Information theoretic way of thinking in genome assembly and cryptocurrency (David Tse)
- lecture 19: Intro to quantum information theory (Yihui Quek)
- lecture 20: Science of information in entertainment and web 3.0 (Jonathan Dotan)

in-class lectures

- main concepts and intuition
- applications
- pointers to video segments for more details and rigor
- prereq: probability, conditional probability, expectation, etc.

course work

- HW
- project
- outreach
- wellbeing

HW

approximately weekly, first 2/3 of the quarter

questions will be classified to categories:

- doable by everyone with the prereq who attended the lectures
- doable by everyone with the prereq who attended the lectures + viewed the video segments
- doable by those with a stronger mathematical background

project

either:

- tell us your background and interests and we will tailor a project, group, etc.

or:

- tell us your choice of a project from the list we provided

or:

- suggest to us a concrete project not from the list: who, what, how, etc.

project mentors

- Shubham Chandak



- Irena Fischer-Hwang



- Yanjun Han



- Ariana Mann

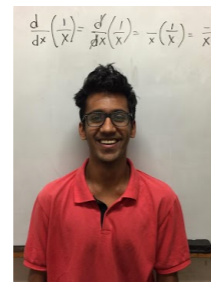

- Jay Mardia

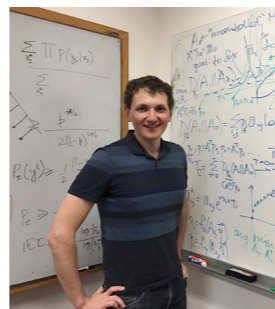

- Dmitri Pavlichin

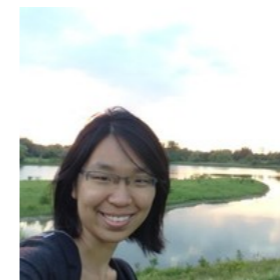

- Yihui Quek



- Kedar Tatwawadi



- Meltem Tolunay



- Tsachy Weissman

each group will be assigned a mentor

project ideas

- see project ideas by the mentors
- not all are run of the mill
- projects for everyone: mathematicians, machine/deep learning aficionados, coders, musicians, artists, illustrators, linguists, composers, Artificial Intelligence people, hardware people, chemists and chemical engineers, natural language processing, data scientists, builders, writers, roboticists, linguists, mechanical engineers, neuroscientists, journalists, science communicators, actors, historians, community organizers, web developers, documentarians, marketing people, cartoonists, radio hobbyists, biologists, educators, etc.

outreach

- Lucille M. Nixon Elementary School
- Saturday, March 16th, 5pm-7pm
- “science and engineering of information” night
- each project group required to participate with booth / activity

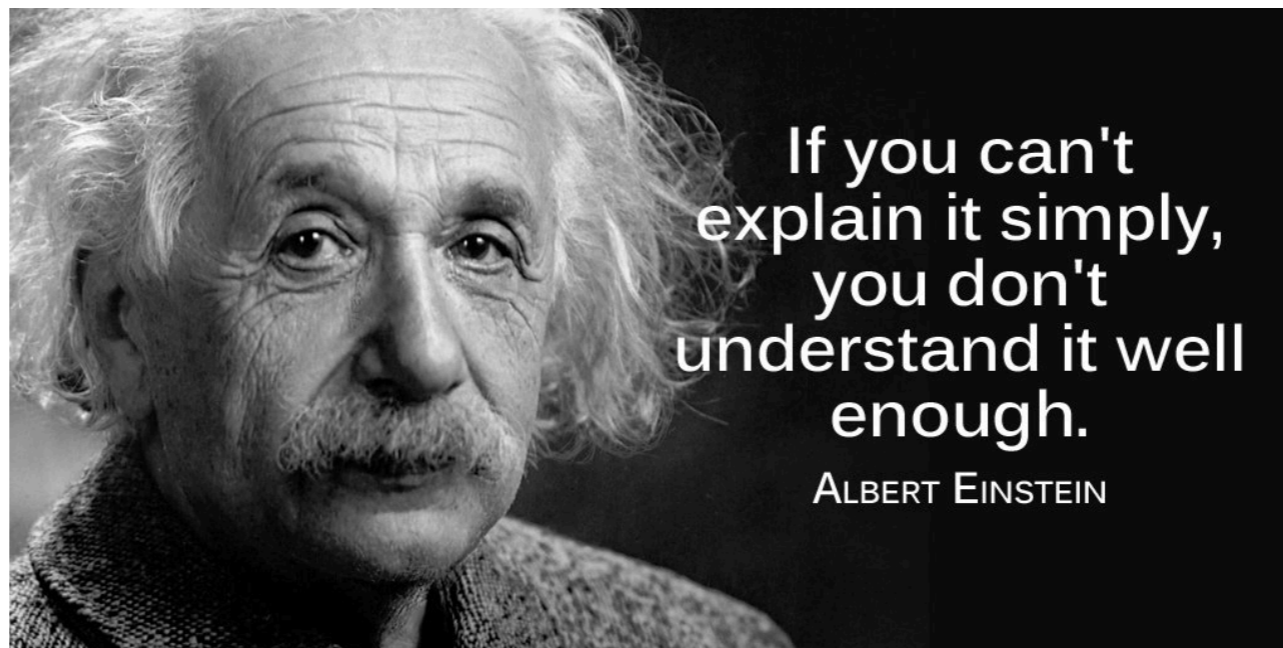

your project can be outreach oriented

for example, can create/write/build/plan/prepare/organize/start:

- podcast
- children's book
- comic book
- machine (e.g. Rube Goldberg machine for communicating one bit)
- doodle video
- a summer internship program for high schoolers
- script for show/play/movie
- art (ceramics, painting, acting) that tells the story of communication
- about communication with aliens (astronomers)
- journalistic piece (in writing, video, etc.)
- major activity at the outreach event
- the outreach event itself
- a Science of Information journal/journal for youth/blog
- about the ethical use of information

wellbeing

- work proactively on being comfortable, healthy, and happy
- reduce stress
- examples: meditation, reading a book, hiking, playing the piano, playing a game, meeting a friend, etc.

dates & deliverables

- write to us with a short description of your background and interests. if you have a specific project and team in mind, let us know about that as well (by 1/18)
- we tell you who is in your project group and meet to clearly define your project (by 1/25)
- work on project (throughout quarter)
- short milestone report or discussion with the staff (mid february)
- attend the Stanford compression workshop (2/15)
- participate at the Nixon elementary school outreach night (3/16, right at the end of the quarter, before exam period)
- write a blogpost reporting on/describing your project+outreach activity and send us the link (by 3/24)

staff

- Instructor: Tsachy Weissman
- TAs: Shubham Chandak, Meltem Tolunay
- Project mentors: Shubham Chandak, Irena Fischer-Hwang, Yanjun Han, Ariana Mann, Jay Mardia, Dmitri Pavlichin, Yihui Quek, Kedar Tatwawadi, Meltem Tolunay, Tsachy Weissman
- more details on the course website & Piazza & Canvas, etc.

we're here to support

- guidance and feedback
- materials, equipment, facilities, publishing etc.
- organization
- moral support

grade

you assign weights to:

- HW, project, outreach, wellbeing

such that:

- outreach $\geq 5\%$
- project+outreach $\geq 60\%$
- wellbeing $\geq 25\%$

grading criteria:

- how seriously did you take and work on these elements?
- how effective were you?

you are most qualified to answer these questions, so ***you*** give yourself your final grade

why outreach & blog?

- give back for good karma
- if a tree falls in a forest with no one around to hear it, does it make a sound?
- no information without communication

dates & deliverables

- write to us with a short description of your background and interests. if you have a specific project and team in mind, let us know about that as well (by 1/18)
- we tell you who is in your project group and meet to clearly define your project (by 1/25)
- work on project (throughout quarter)
- short milestone report or discussion with the staff (mid february)
- attend the Stanford compression workshop (2/15)
- participate at the Nixon elementary school outreach night (3/16, right at the end of the quarter, before exam period)
- write a blogpost reporting on/describing your project+outreach activity, send us the link, and write to us with your final grade (by 3/24)



with thanks to Hadar and Shyloh

Questions?